

## Female Pipe (N.P.T.) X Female Pipe (N.P.T.)

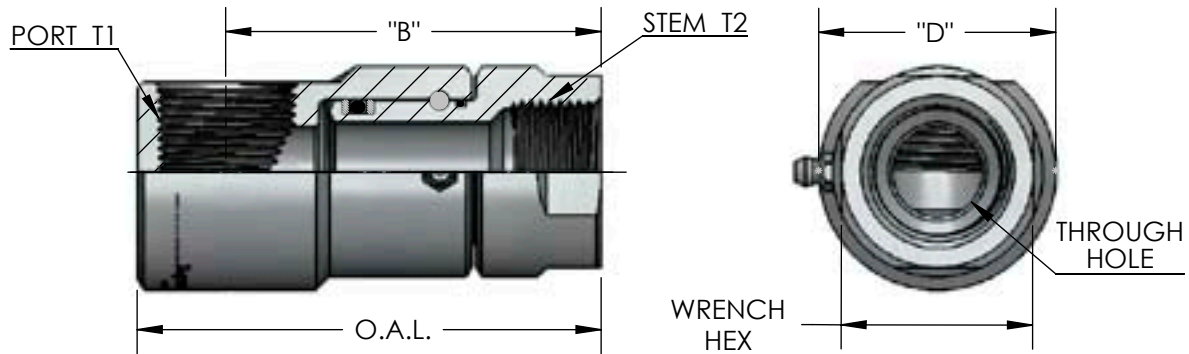

PART NUMBER	O.A.L.	DIM. B	DIM. D Ø	WRENCH/HEX	PORT T1	STEM T2	SWG. RADIUS	MAX. P.S.I.G.	THROUGH HOLE
9 SS 2 FP 12.5 X FP 12.5	1.784	1.524	0.879	0.625	1/8-27 N.P.T.	1/8-27 N.P.T.	0.375	5000	0.157
9 SS 4 FP 25 X FP 25	2.712	2.345	1.192	0.875	1/4-18 N.P.T.	1/4-18 N.P.T.	0.525	5000	0.250
9 SS 8 FP 38 X FP 38	2.970	2.423	1.495	1.125	3/8-18 N.P.T.	3/8-18 N.P.T.	0.588	5000	0.530
9 SS 8 FP 50 X FP 50	2.970	2.423	1.495	1.250	1/2-14 N.P.T.	1/2-14 N.P.T.	0.588	5000	0.530
9 SS 12 FP 75 X FP 75	3.180	2.515	1.710	1.500	3/4-14 N.P.T.	3/4-14 N.P.T.	0.662	4500	0.609
9 SS 16 FP 100 X FP 100	4.225	3.417	2.162	1.750	1-11 1/2 N.P.T.	1-11 1/2 N.P.T.	0.824	4000	0.827
9 SS 20 FP 125 X FP 125	4.748	3.780	2.702	2.125	1 1/4-11 1/2 N.P.T.	1 1/4-11 1/2 N.P.T.	1.049	4000	1.181
9 SS 24 FP 150 X FP 150	5.890	4.660	2.917	2.375	1 1/2-11 1/2 N.P.T.	1 1/2-11 1/2 N.P.T.	1.076	4000	1.312
9 SS 32 FP 200 X FP 200	6.730	5.390	3.667	2.875	2-11 1/2 N.P.T.	2-11 1/2 N.P.T.	1.386	3000	1.781

## Male Pipe (N.P.T.) X Female Pipe (N.P.T.)

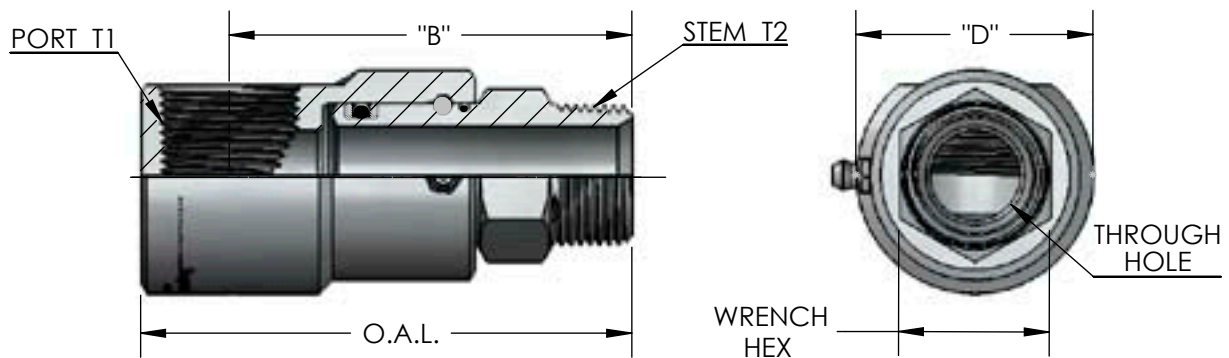

PART NUMBER	O.A.L.	DIM. B	DIM. D Ø	WRENCH/HEX	PORT T1	STEM T2	SWG. RADIUS	MAX. P.S.I.G.	THROUGH HOLE
9 SS 2 MP 12.5 X FP 12.5	1.855	1.595	0.879	0.437	1/8-27 N.P.T.	1/8-27 N.P.T.	0.375	5000	0.157
9 SS 4 MP 25 X FP 25	2.837	2.470	1.192	0.625	1/4-18 N.P.T.	1/4-18 N.P.T.	0.525	5000	0.250
9 SS 4 MP 38 X FP 25	2.837	2.470	1.192	0.750	1/4-18 N.P.T.	3/8-18 N.P.T.	0.525	5000	0.250
9 SS 7 MP 38 X FP 38	3.085	2.527	1.357	0.750	3/8-18 N.P.T.	3/8-18 N.P.T.	0.565	5000	0.406
9 SS 8 MP 38 X FP 38	3.095	2.548	1.495	1.000	3/8-18 N.P.T.	3/8-18 N.P.T.	0.588	5000	0.406
9 SS 8 MP 50 X FP 50	3.220	2.673	1.495	1.000	1/2-14 N.P.T.	1/2-14 N.P.T.	0.588	5000	0.530
9 SS 12 MP 75 X FP 75	3.430	2.765	1.710	1.125	3/4-14 N.P.T.	3/4-14 N.P.T.	0.643	4500	0.609
9 SS 16 MP 100 X FP 100	4.475	3.667	2.162	1.375	1-11 1/2 N.P.T.	1-11 1/2 N.P.T.	0.824	4000	0.827
9 SS 20 MP 125 X FP 125	4.873	3.905	2.702	1.750	1 1/4-11 1/2 N.P.T.	1 1/4-11 1/2 N.P.T.	1.049	4000	1.181
9 SS 24 MP 150 X FP 150	6.185	4.955	2.917	2.125	1 1/2-11 1/2 N.P.T.	1 1/2-11 1/2 N.P.T.	1.076	4000	1.312
9 SS 32 MP 200 X FP 200	7.105	5.765	3.667	2.500	2-11 1/2 N.P.T.	2-11 1/2 N.P.T.	1.386	3000	1.781